

## Technical Specifications - CAST IRON BUTTERFLY VALVES (Flanged Type)

<b>Type of Valve</b>	Butterfly Valve Short Body, Worm Gear, Flanged Type	
<b>Materials of Construction:</b>		
a. Body	CI to IS 210 Gr. Fg 200/260	
b. Disc	CI to IS 210 Gr. Fg 200/260	
c. Drive Shaft	SS 410	
d. Stub Shaft	SS 410	
e. Shaft Bearing	Bronze To 318 LTB 2	
f. Body Seat	Stainless Steel	
g. Shaft Seal	Nitrile Rubber	
h. Disc Screw	Stainless Steel	
i. Indicating Plate	MS to IS 2062 Gr A	
j. Seat Retainer	Stainless Steel	
k. Hand Wheel	CI to IS 210 Gr. Fg 200	
l. Disc Seat	Nitrile Rubber	
m. End Cover Plate	MS to IS 2062 Gr. A	
n. Thrust Pad	Bronze To 318 LTB 2	
<b>Design</b>	BS:5155 / Is 13095 / BSEN 593	
<b>Dimension</b>		
• Face-to-Face	BS:5155 / Is 13095	
• Ends	Flanged to customer requirement	
<b>Hydraulic test pressure:</b>		
• Rating	PN 10 / 1.0	PN 16 / 1.6
• Body	15 Kg/Cm <sup>2</sup>	24 Kg/ Cm <sup>2</sup>
• Seat	10 Kg/ Cm <sup>2</sup>	16 Kg/ Cm <sup>2</sup>
<b>Range</b>	150 mm NB to 1200 mm NB	

**Part Name:**

1. Body
2. Disc
3. Drive Shaft
4. Stub Shaft
5. Shaft Bearing ( Bush)
6. Body Seat
7. Shaft Seal' O ' Ring
8. Disc Screw
9. Disc Seat
10. Lever
11. Hand Wheel
12. Worm Gear (1/4 Turn)
13. Seat Retainer
14. End Cover Plate
15. Thrust Pad

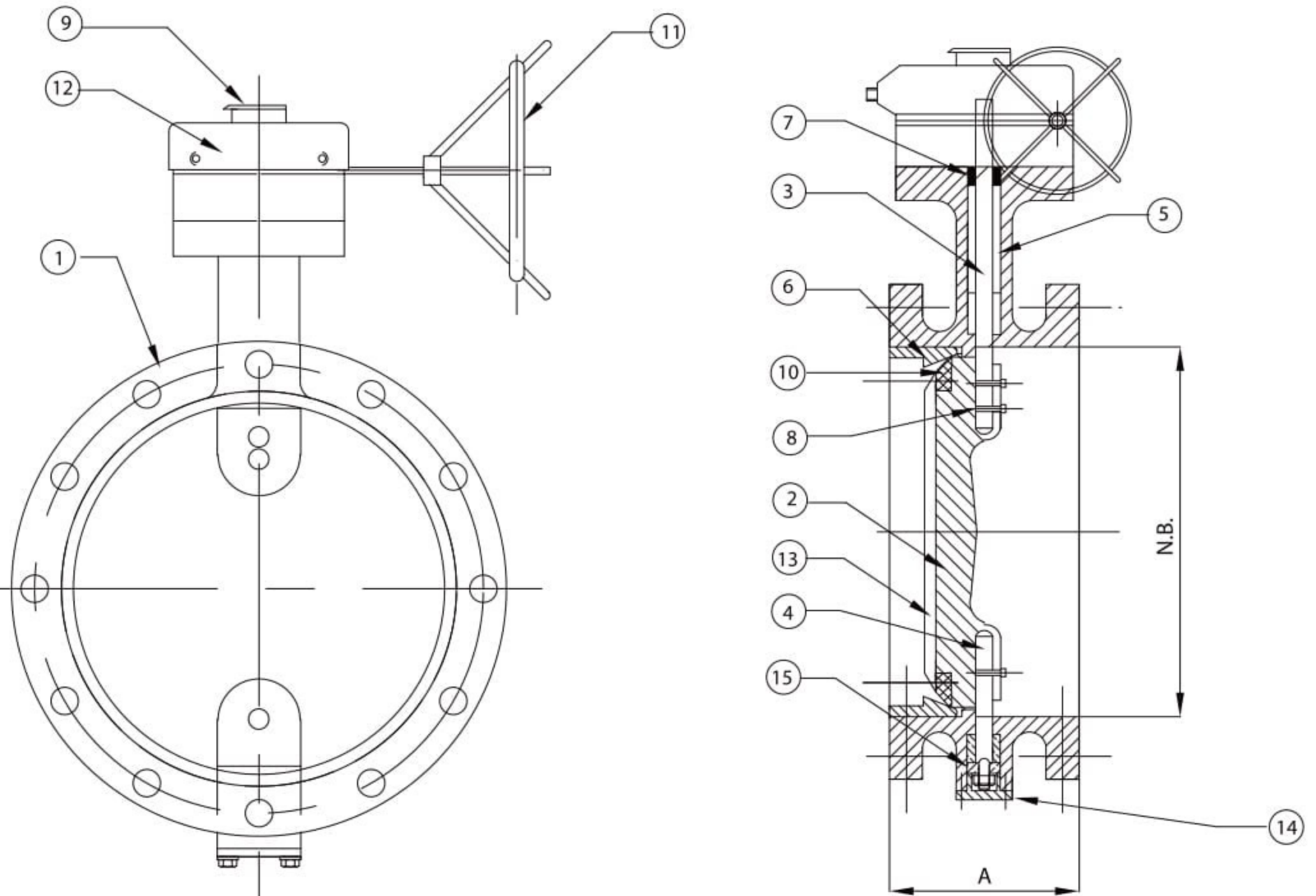

- Note**
- Description given is generalized, may vary as per requirement.
  - Specifications given above are subject to change as per revisions in standards without notice.
  - Quotations are based on customer's requirement and data. Customers are requested to send specific requirement for an offer.
  - All sizes in millimeter

**H. Sarker & Company Valves (P) Ltd.**

**Works:** Phone: +91 33 2653 1214 / 0061 • eMail: hsblt09@gmail.com

**Regd. Office:** Ajit Sen Bhawan, 13 Crooked Lane, 2nd Floor, Kolkatta 700 069.

Phone: 033-22109163

